

Basic Concepts(I)

- ⌘ **Cryptology**
 - = Crypto(Hidden) + Logos (word)
 - = Cryptography + Cryptanalysis
 - = Code Writing + Code Breaking
- ⌘ **Encryption(Decryption),Key,Plaintext,Ciphertext, Deciphertext**

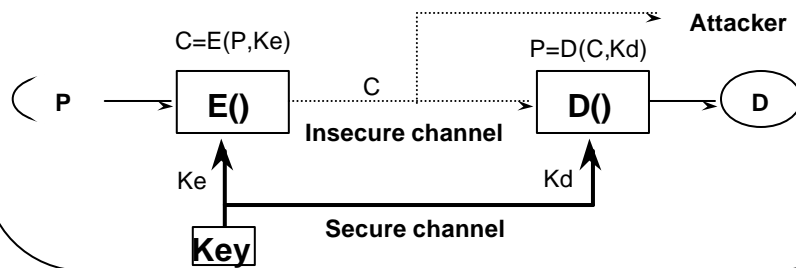

1

Basic Concept(II)

- ⌘ **Channel**
 - Secure : trust, registered mail, tamper-proof device
 - Insecure : open, public channel
- ⌘ **Entity**
 - Sender (Alice)
 - Receiver (Bob)
 - Adversary (Charlie)
 - ⌘ Passive attack : wiretapping -> Privacy
 - ⌘ Active attack : modification, impersonation -> Authentication

2

Basic Concepts(III)

✍ Classification of cryptoalgorithms

– by date

- ✍ Traditional(~19C) : Ceaser
- ✍ Mechanical(WW I, II) : Rotor Machine, Purple
- ✍ Modern('50~) : DES, IDEA, AES

– by number of keys

- ✍ Conventional : {1, single, common} key, symmetric
- ✍ Public key cryptosystem : {2, dual} keys, asymmetric

– by size of plaintext

- ✍ Block Cipher
- ✍ Stream Cipher

3

Classification of Security

- ✍ Unconditionally secure : unlimited power of adversary, perfect (Ex : one-time pad)
- ✍ Complexity-theoretic secure : complexity theoretic, adversary with polynomial-time power
- ✍ Provably secure
- ✍ Computationally secure
- ✍ Feasible secure

4

Block Cipher

✎ Characteristics

- **Based on Shannon's Theorem(1949)**
 - ✎ Repetitive use of Confusion (Substitution) and Diffusion (Permutation)
 - ✎ Iteration : Weak -> Strong
- **Same P => Same C**
- **{|P| = |C|} ? 64 bit, |P| ? |K| ? 56 bit**
- **Memoryless configuration**
- **Operate as stream cipher depending on mode**
- **Shortcut cryptanalysis (DC, LC etc) in 90's**

* DC :Differential Cryptanalysis, LC : Linear Cryptanalysis

(c)ICU Kwangjo Kim

5

Design Criteria of DES

- ✎ Provide a high level of security
- ✎ Completely specify and easy to understand
- ✎ Security must depend on key, not algorithm
- ✎ Available to all users
- ✎ Adaptable for use in diverse applications
- ✎ Economically implementable in electronic device
- ✎ Efficient to use
- ✎ Able to be validated
- ✎ Exportable

* Federal Register, May 15, 1973

(c)ICU Kwangjo Kim

6

Structure of DES

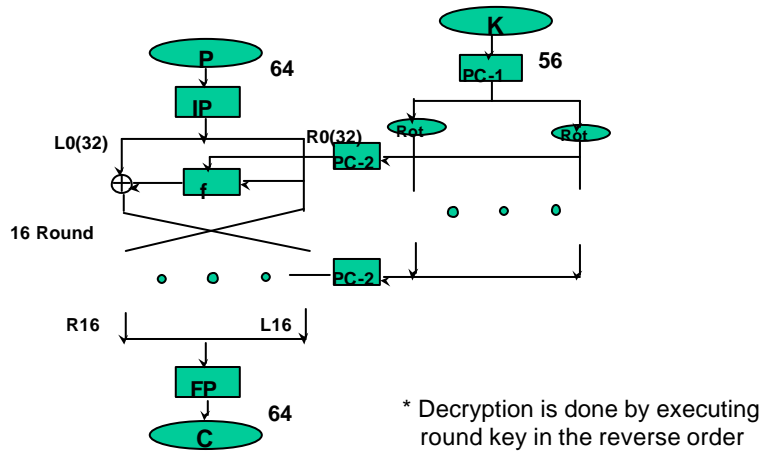

(c)ICU Kwangjo Kim

7

f-function of DES

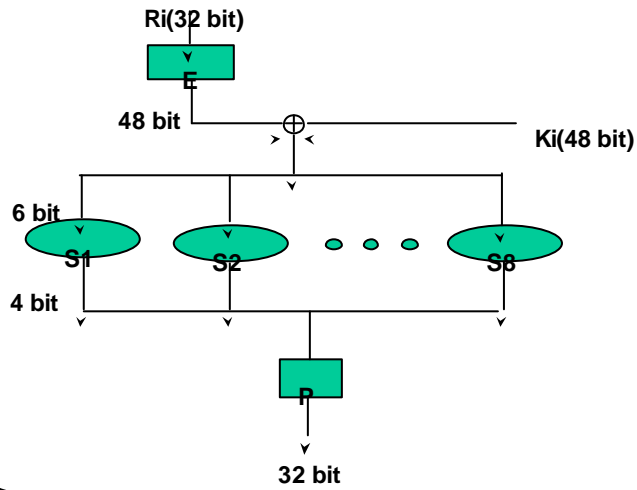

(c)ICU Kwangjo Kim

8

Criticism of DES

- ✂ **Short key size : 112 -> 56 bits by NSA**
- ✂ **Classified design criteria**
- ✂ **Hidden trapdoor**
- ✂ **Revision of standard every 5 yrs after 1977 by NIST**

(c)ICU Kwangjo Kim

9

DES Key Search Machine

- ✂ **Diffie & Hellman ('77)**
 - 10^6 keys/sec VLSI
 - Cost = \$20,000,000
- ✂ **Wiener ('93)**
 - 5×10^7 keys/sec
 - 1 Frame : $10\$/\text{VLSI} \times 5,760 = \$100,000$
 - 10 Frames : \$1,000,000
 - 3.5hr in average

(c)ICU Kwangjo Kim

10

DES Challenge(I)

- ✍ **RSA Data Security Inc's protest against US's export control('97)**
 - \$10,000('97) award
 - Key search machine by Internet Loveland's Rocker Verser
 - 60.1 Billion/1 day Key search, Succeed in 18 quadrillion operations and 96 day
 - ✍ 25% of Total 72 quadrillion ($1q=10^{15}=0.1$)
 - ✍ 90MHz, 16MB Memory Pentium(700 Million/sec)
 - <http://www.rsa.com/des/>

(c)ICU Kwangjo Kim

11

DES Challenge(II, III)

- ✍ **Distributed.Net + EFF**
 - 100,000 PC on Network
 - 56hr
- ✍ **EFF**
 - <http://www.eff.org/DES> cracker
 - Specific tools
 - 22hr 15min
 - 250,000\$



(c)ICU Kwangjo Kim

12

Strengthening DES

✎ Key size expansion

– Double Encryption

✎ $e_k: E_2(K_2, E_1(K_1, P)), d_k: D_1(K_1, D_2(K_2, C))$

✎ Meet-in-the-middle attack

✎ No increase of practical key size

– Triple Encryption

✎ $e_k: E(K_1, D(K_2, E(K_1, P))), d_k: D(K_1, E(K_2, D(K_1, C)))$

✎ $e_k: E(K_1, D(K_2, E(K_3, P))), d_k: D(K_3, E(K_2, D(K_1, C)))$

✎ 112 or 168 bits

(c)ICU Kwangjo Kim

13

Summary of block ciphers

Algorithm	Year	Country	Pt/Ct	Key	Round
DES	1977	USA	64	56	16
FEAL	1987	Japan	64	64	4,8,16,32
GOST	1989	Russia	64	256	32
IDEA	1990	Swiss	64	128	8
LOKI	1991	Australia	64	64	16
SKIPJACK	1990	USA	64	80	32
MISTY	1996	Japan	64	128	>8
SEED	1998	Korea	128	128	16

14

AES requirements

- ✍ **Block cipher**
 - 128-bit blocks
 - 128/192/256-bit keys
- ✍ **Worldwide-royalty free**
- ✍ **More secure than Triple DES**
- ✍ **More efficient than Triple DES**

(c)ICU Kwangjo Kim

15

AES Calendar

- Jan. 2, 1997 : Announcement of intent to develop AES and request for comments
- Sep. 12, 1997 : Formal call for candidate algorithms
- Aug. 20-22, 1998 : First AES Candidate Conference and beginning of Round 1 evaluation (15 algorithms), Rome, Italy
- Mar. 22-23, 1999 : Second AES Candidate Conference, NY, USA
- Sep. 2000 : Final AES selection

Jan. 1997
Call for
algorithms

Aug. 1998
AES1
15 algorithms

Mar. 1999
AES2
5 algorithms selected

Apr. 2000
AES3
Announce winner
in Sep, 2000

(c)ICU Kwangjo Kim

16

AES1 algorithms

15 algorithms are proposed at AES1 conference

Cipher	Submitted by	Country
CAST-256	Entrust	Canada
Crypton	Future Systems	Korea [†]
Deal	Outerbridge	Canada [†]
DFC	ENS-CNRS	France
E2	NTT	Japan
Frog*	TecApro	Costa Rica
HPC*	Schroepel	USA
LOKI97*	Brown, Pieprzyk, Seberry	Australia
Magenta	Deutsche Telekom	Germany
Mars	IBM	USA [†]
RC6	RSA	USA [†]
Rijndael*	Daemen, Rijmen	Belgium [‡]
Safer+*	Cylink	USA [†]
Serpent*	Anderson, Biham, Knudsen	UK, Israel, Norway
Twofish*	Counterpane	USA [†]

* Placed in the public domain; † and foreign designers; ‡ foreign influence

(c)ICU Kwangjo Kim

17

AES Round 2 Algorithms

After AES2 conference, NIST selected the following 5 algorithms as the round 2 candidate algorithm.

Algorithm Name	Submitter Name(s)
MARS	IBM (represented by Nevenko Zunic)
RC6™	RSA Laboratories (represented by Burt Kaliski)
Rijndael	Joan Daemen, Vincent Rijmen
Serpent	Ross Anderson, Eli Biham, Lars Knudsen
Twofish	Bruce Schneier, John Kelsey, Doug Whiting, David Wagner, Chris Hall, Niels Ferguson

(c)ICU Kwangjo Kim

18

Operation of E/D device

(1) link-by-link

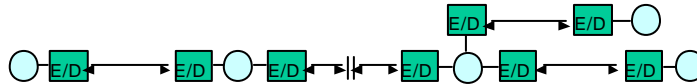

Ex : M/W Link, Satellite Link etc

(2) end-to-end

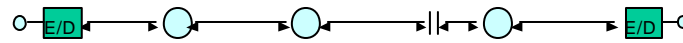

Ex : Telephone, Fax, Data Terminal etc

(3) Hybrid operation: (1) + (2)

(c)ICU Kwangjo Kim

19

Problem of Symmetric Cryptosystems

Key management

- ⌘ Keep secret key in secret
- ⌘ Over complete graph with n nodes,
 ${}_n C_2 = n(n-1)/2$ pairs secret keys are required.
- ⌘ (Ex) $n=100, 99 \times 50 = 4,950$ keys

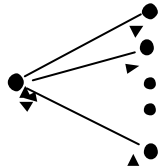

(c)ICU Kwangjo Kim

20

Concepts of PKC(I)

✍ 1-way ft.

- ✍ Given x , easy to compute $f(x)$.
- ✍ Difficult to compute $f^{-1}(x)$ for given $f(x)$.

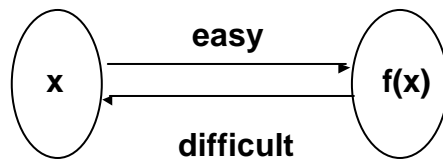

Ex) $f(x) = x^5 + x^3 + x^2 + 1$

(c)ICU Kwangjo Kim

21

Concepts of PKC(II)

✍ Keyed 1-way ft : 1-way ft with a key

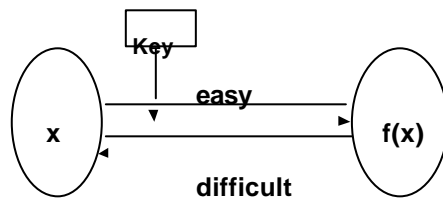

(c)ICU Kwangjo Kim

22

Concepts of PKC(III)

1-way trapdoor ft.

- Given x , easy to compute $f(x)$
- Easy to compute $f^{-1}(x)$ for given $f(x)$ and some information \rightarrow trapdoor information

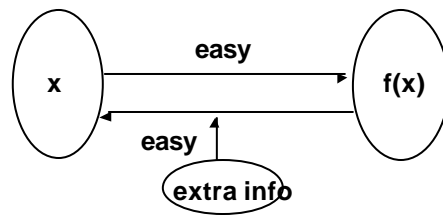

(c)ICU Kwangjo Kim

23

Concepts of PKC(IV)

Use two keys

- Given public key, easy to compute \rightarrow anyone can lock.
- Only those has secret key, compute inverse \rightarrow only who has it can unlock, vice versa.

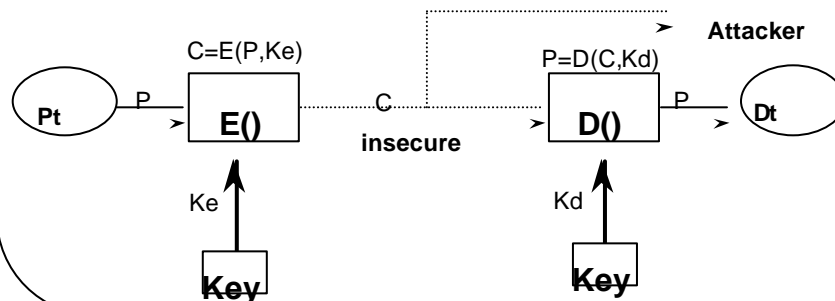

(c)ICU Kwangjo Kim

24

What service PKC provides ?(I)

✍ For Privacy

- Encrypt M with Bob's public key : $C = e_K(B_p, M)$

- Decrypt C with Bob's private key : $D = d_K(B_s, C)$

* Anybody can generate C, but only B can recover C.

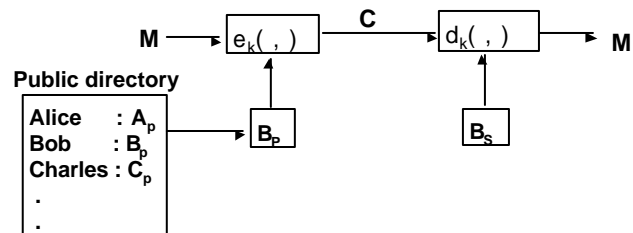

(c)ICU Kwangjo Kim

25

What service PKC provides ?(II)

✍ For authentication(Digital Signature)

- Encrypt M with Alice's private key : $C = d_K(A_s, M)$

- Decrypt C with Alice's public key : $D = e_K(A_p, C)$

* Only Alice can generate C, but anybody can recover C.

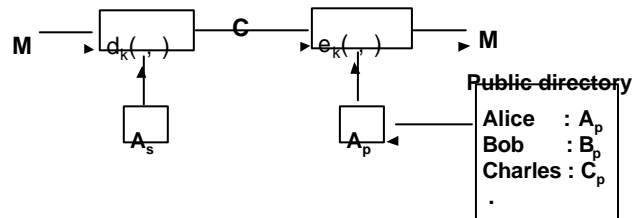

(c)ICU Kwangjo Kim

26

What service PKC provides ?(III)

- ✍ Identification
- ✍ Non-Repudiation
- ✍ Applicable to various cryptographic protocols
- ✍ Hybrid use with symmetric cryptosystem

(c)ICU Kwangjo Kim

27

Comparision

Cryptosystem Item	Symmetric	Asymmetric
Key relation	Enc. key = Dec. key	Enc. Key ? Dec. key
Enc. Key	Secret	Public, {private}
Dec. key	Secret	Private, {public}
Algorithm	Secret Public	Public
Typical ex.	Skipjack DES	RSA
Key Distribution	Req'd (X)	Not req'd (O)
Number of keys	Many(X), keep many partners' secret key	Low(O), keep his pri. Key only
Secure authentication	Hard(X)	Easy(O)
E/D Speed	Fast(O)	Slow(X)

(c)ICU Kwangjo Kim

28

RSA Scheme(I)

- ✍ For large 2 primes p, q
- ✍ $n=pq, \phi(n)=(p-1)(q-1)$: Euler phi ft.
- ✍ Select random e s.t. $\gcd(\phi(n), e) = 1$
- ✍ Compute $ed = 1 \pmod{\phi(n)} \rightarrow ed = k\phi(n) + 1$
- ✍ Public key = $\{e, n\}$, secret key = $\{d, \{n\}\}$
- ✍ For given M in $[0, n-1]$,
- ✍ Encryption, $C = M^e \pmod n$
- ✍ Decryption, $D = C^d \pmod n$
- (Proof) $C^d = (M^e)^d = M^{ed} = M^{k\phi(n)+1} = M \{M^{\phi(n)}\}^k = M$

(c)ICU Kwangjo Kim

29

RSA Scheme(II)

- ✍ $p=3, q=11$
- ✍ $n = pq = 33, \phi(n) = (p-1)(q-1) = 2 \times 10 = 20$
- ✍ $e = 3$ s.t. $\gcd(e, \phi(n)) = \gcd(3, 20) = 1$
- ✍ Choose d s.t. $ed = 1 \pmod{\phi(n)}, 3d = 1 \pmod{20}, d=7$
- ✍ Public key = $\{e, n\} = \{3, 33\}$, private key = $\{d\} = \{7\}$

- ✍ $M = 5$
- ✍ $C = M^e \pmod n = 5^3 \pmod{33} = 26$
- ✍ $M = C^d \pmod n = 26^7 \pmod{33} = 5$

(c)ICU Kwangjo Kim

30

Requirements of Digital Signature

- ✍ Efficiency
- ✍ Unforgeability : only signer can generate
- ✍ Authentication of a signer:
- ✍ Not reusable : not to use for other message
- ✍ Unalterable : No modification of signed message
- ✍ Non-repudiation : not denying the act of signing

(c)ICU Kwangjo Kim

31

Elements of Digital Signature

- ✍ Consists of 6 elements (M, Mh, A, K, S, V)
 - ✍ M : message space
 - ✍ Mh (or Ms) : signing space
 - ✍ A : signature space
 - ✍ K : key space
 - ✍ For K ? K , ? signing alg. sig_K ? S and its corresponding verification alg. ver_K ? V .
 - ✍ Each $sig_K: M \rightarrow A$ and $ver_K: M \times A \rightarrow \{t, f\}$ are fts s.t., $ver_K(x, y) = t$ if $y = sig_K(x)$ or $ver_K(x, y) = f$ if $y \neq sig_K(x)$

(c)ICU Kwangjo Kim

32

Digital signature with appendix(I)

(1) Signature generation

(a) get secret key, K_s

(b) $m'=h(m)$: hash algorithm and $s^*=\text{sig}_{K_s}(m')$

(c) m, s^* : signature

(2) Signature verification

(a) obtain public key, K_p

(b) compute $m'=h(m)$ and $u=\text{ver}_{K_p}(m',s^*)$

(c) accept signature iff $u=\text{true}$.

(Ex.) DSA, ElGamal, Schnorr

(c)ICU Kwangjo Kim

33

Digital signature with appendix(II)

(a) signing

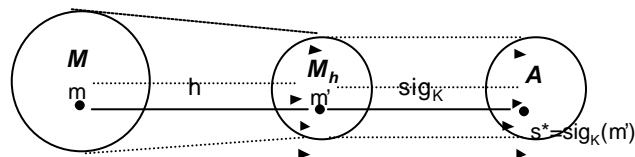

(b) verification

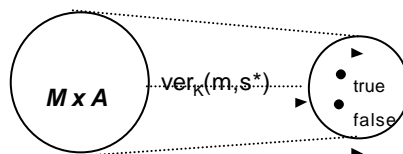

(c)ICU Kwangjo Kim

34

Digital signature with message recovery(I)

(1) Signature generation

(a) get secret key, K_s

(b) $m' = R(m)$: redundancy ft and $s^* = \text{sig}_{K_s}(m')$

(c) s^* : signature

(2) Signature verification

(a) obtain public key K_p

(b) compute $m' = \text{ver}_{K_p}(s^*)$

(c) verify that $m' \neq M_R$ (if $m' = M_R$, then reject)

(d) recover m from m' by computing $R^{-1}(m')$

(Ex.) RSA, Rabin, Nyberg-Rueppel

* $R()$ and $R^{-1}()$ are easy to compute.

(c)ICU Kwangjo Kim

35

Digital signature with message recovery(II)

(a) signing

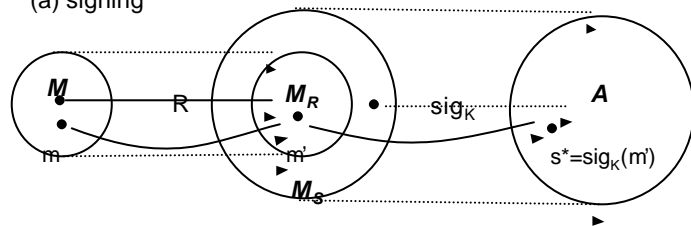

(b) verification

Omitted.

R: redundancy ft
e.g., 1:1 ft
 M_R : image of R

*This scheme can be easily changed to digital signature with appendix
s.t., hashing before signing.

(c)ICU Kwangjo Kim

36

Comparison of Signature

Item	Handwritten	Digital
Result of Signature	Fixed	Variable
Digital Copy	Difficult	Easy
Operation	Simple	Mathematical
Legality	Yes	Yes
Forgeability	Possible	Impossible
Tool	Pen	Computer
Auxiliary Tool	Not Necessary	Necessary(Hash ft)

(c)ICU Kwangjo Kim

37

Applied Digital Signature

- ✍ **Blind signature**
- ✍ **One-time signature**
 - Lamport scheme
 - Bos-Chaum scheme
- ✍ **Undeniable signature**
 - Chaum-van Antwerpen scheme
- ✍ **Fail-stop signature**
 - van Heyst-Peterson scheme
- ✍ **Group Signature** : group member can generate signature if dispute occurs, identify member.

(c)ICU Kwangjo Kim

38

Chaum's Blind Signature(I)

- Without B's knowing message M itself, A can get a signature of M from B.
- RSA scheme, B's public key $\{n,b\}$, secret key: $\{a\}$

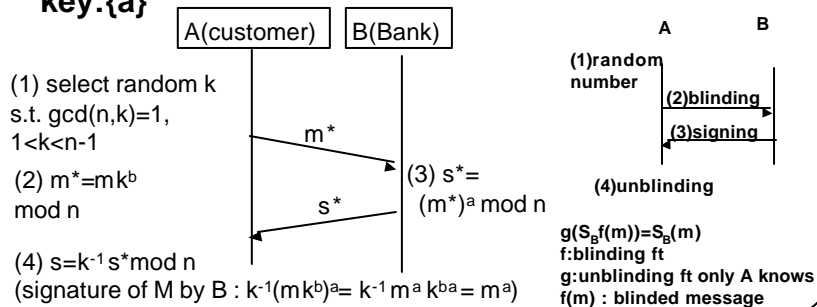

(c)ICU Kwangjo Kim

39

Chaum's Blind Signature(II)

(Preparation) $p=11, q=3, n=33, \phi(n)= 10 * 2=20$
 $\gcd(a, \phi(n))=1 \Rightarrow a=3, ab=1 \text{ mod } \phi(n) \Rightarrow 3b=1 \text{ mod } 20 \Rightarrow b=7$
 B's public key $\{n,b\}=\{33,7\}$, secret key $\{a\}=\{3\}$

- A's blinding of $m=5$
 - select k s.t. $\gcd(k,n)=1 \Rightarrow \gcd(k,33)=1 \Rightarrow k=2$
 - $m^* = m k^b \text{ mod } n = 5 \cdot 2^7 \text{ mod } 33 = 640 = 13 \text{ mod } 33$
 - B's signing
 - $s^* = (m^*)^a \text{ mod } n = 13^3 \text{ mod } 33 = 2197 = 19 \text{ mod } 33$
 - A's unblinding
 - $s = k^{-1} s^* \text{ mod } n$ ($2^{-1} = 17 \text{ mod } 33 \Rightarrow k=17$)
 - $= 17 \cdot 19 \text{ mod } 33 = 323 = 26 \text{ mod } 33$
- * Original Signature : $m^a \text{ mod } n = 5^3 \text{ mod } 33 = 125 = 26 \text{ mod } 33$

(c)ICU Kwangjo Kim

40

Hash function

- ⌘ Compress a binary string with an arbitrary length into a fixed short message
- ⌘ Used for digital signature, integrity, authentication etc.

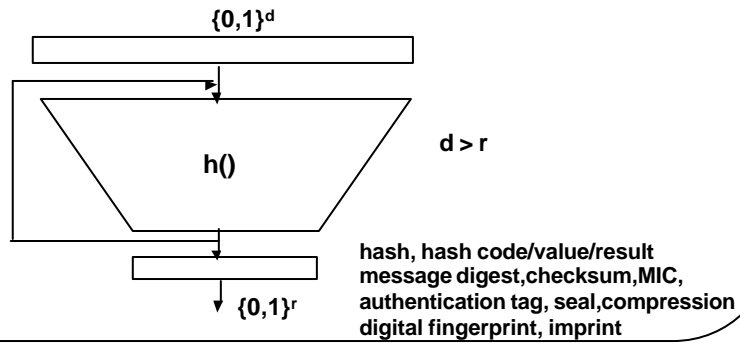

(c)ICU Kwangjo Kim

41

Detailed Configuration of Hash Function

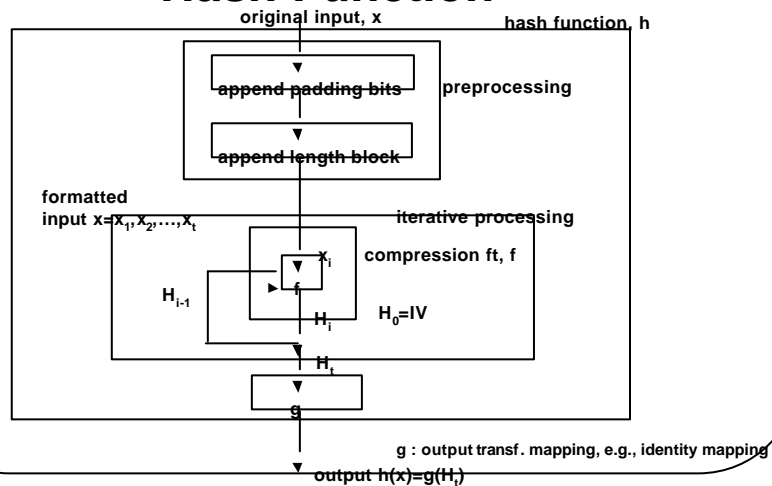

(c)ICU Kwangjo Kim

42

Requirements of Hash function

- ✍ **Compression**
- ✍ **One-wayness**
: If $y=h(x)$ is given, it is computational infeasible to compute x
- ✍ **Collision-free**
: It is computational infeasible to find a pair (x, x') , $x \neq x'$ satisfying $h(x)=h(x')$.
- ✍ **Efficiency**
 - Easy to compute $f(x)$ for a given x .

(c)ICU Kwangjo Kim

43

Classification of Hash ft

- ✍ **Keyed hash : MAC (Message Authentication Code)**
- ✍ **Unkeyed hash : MDC (Manipulation Detection Code),**
 - 1WHF(One Way Hash Function)
 - CFHF(Collision-Free Hash Function)
- ✍ **Dedicated Hash function**
 - MD5, SHA-1

(c)ICU Kwangjo Kim

44

Summary

name	designer	year	characteristics	security
MD4	R.L.Rivest (USA)	'91	Boolean ft 3R, 128bit	collision ('95) 2 ²⁰ operation
MD5	R.L.Rivest (USA)	'92	Boolean ft 4R, 128bit	primitive ft's collision('96)
HAVAL	Y.Zheng (Australia)	'92	expand MD5 3,4,5R/128,160,192,224,256bit	
SHS	NIST	'91	Boolean ft Modified MD4, 4R,160bit	
HAS -160	KISA (Korea)	'98	Boolean ft	

(c)ICU Kwangjo Kim

45

Applications

- ✍ **Used together with a signature scheme**
- ✍ **Integrity service for MIC (Message Integrity Code) (Ex: anti-virus)**
- ✍ **passwd ft in UNIX OS**
- ✍ **Keyed Hash Ft (MAC)**
- ✍ **Identification in Challenge-response protocol**

(c)ICU Kwangjo Kim

46